

**GUIDE TO REPLACING
TAMBOUR SHUTTERS**

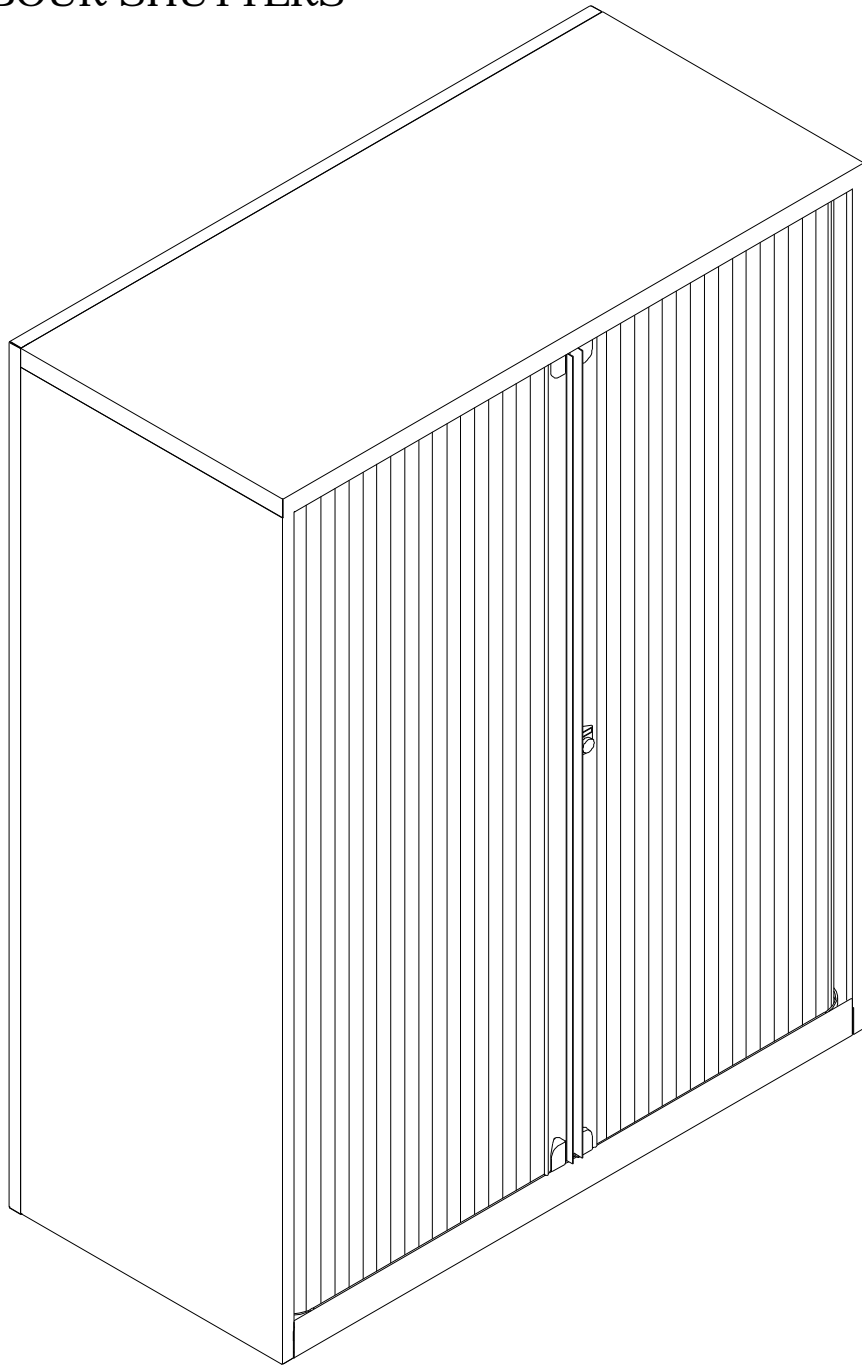

LOOK INSIDE THE UNIT
MAKING SURE THE LEFT
HAND SHUTTER IS
FULLY OPEN AND
REMOVE THE LEFT HAND
STRAIGHT TRACK
SECTIONS AS SHOWN
OVERLEAF

STAGE 1

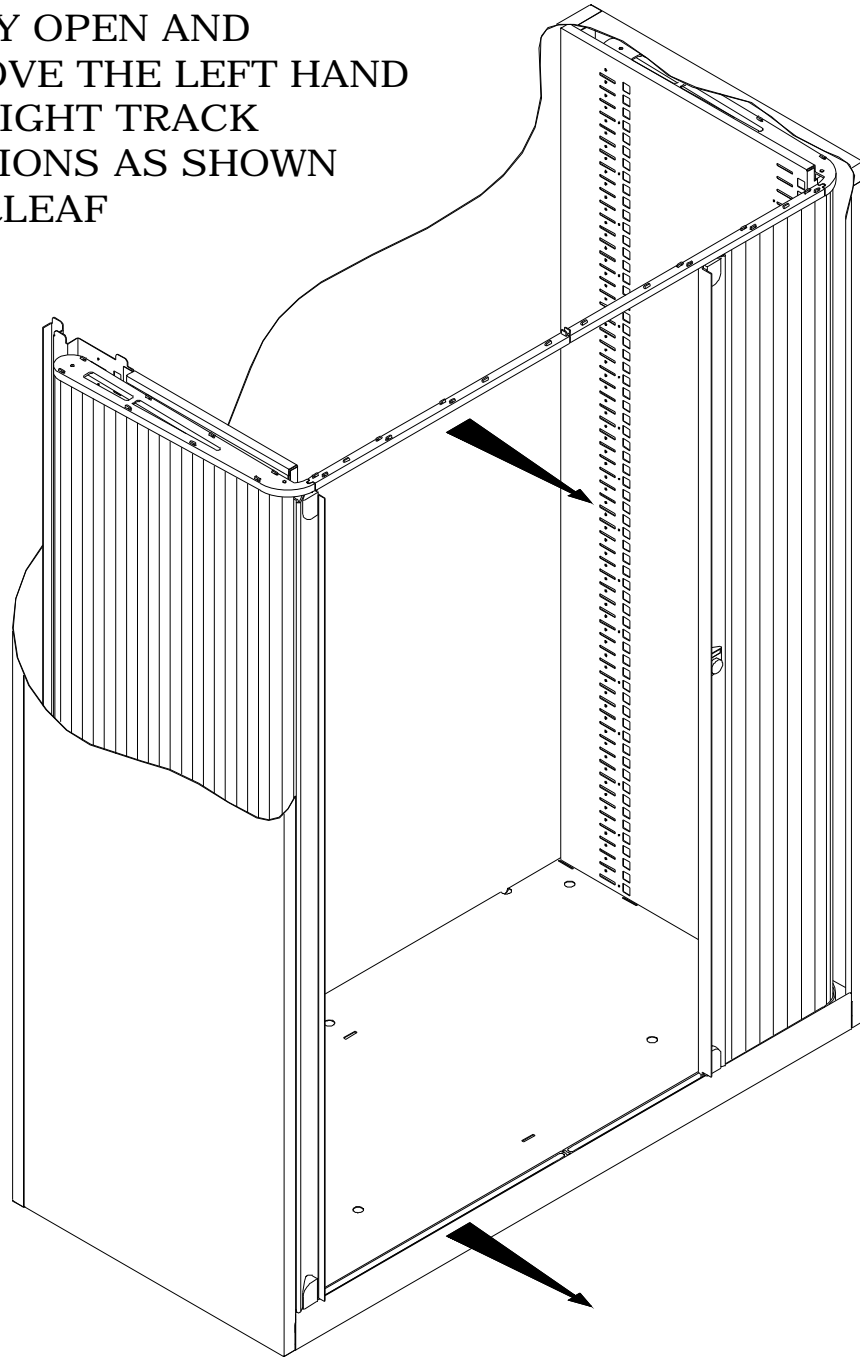

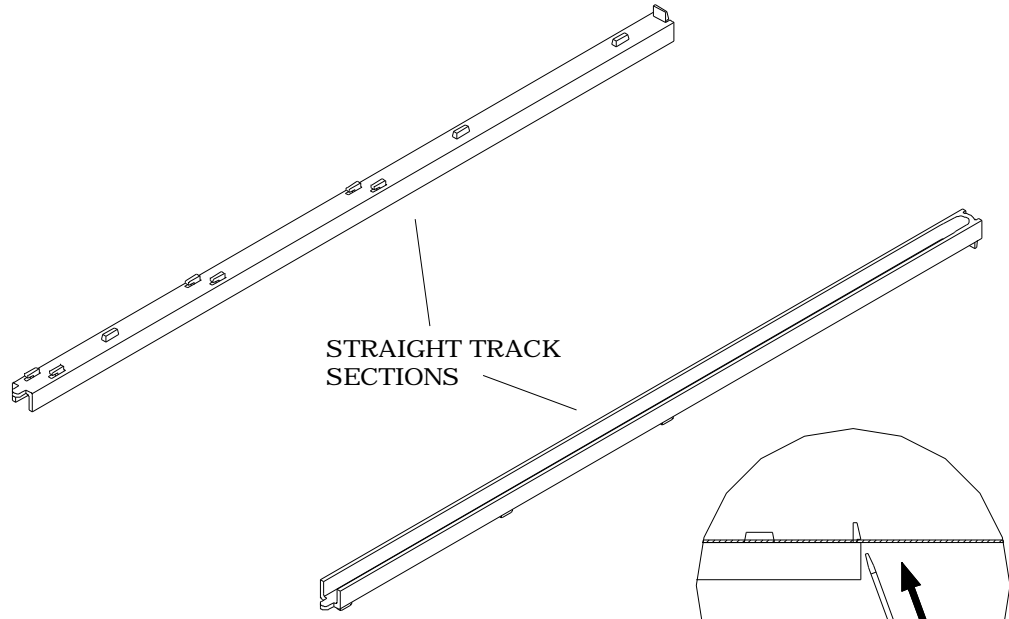

1

TO REMOVE THE STRAIGHT TRACK SECTIONS FIRSTLY USE A SCREW DRIVER TO FREE THE END CLIP. ONCE THE CLIP IS COMPLETELY FREE FROM THE CABINET PULL THE SECTION AWAY AS SHOWN. REPEAT THIS PROCESS AT THE BOTTOM OF THE CABINET

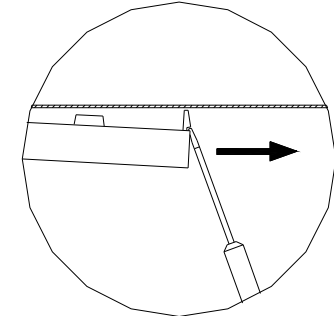
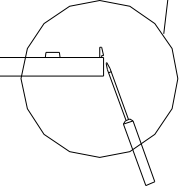
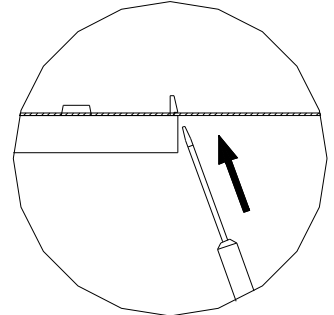

2

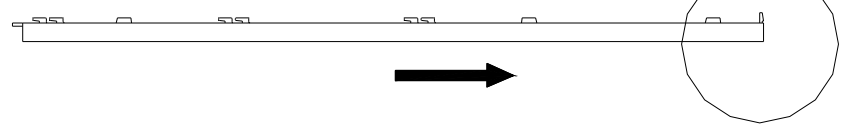

PULL THE SHUTTER OUT
THROUGH THE GAP MADE IN
THE TRACK AND FULLY
REMOVE IT FROM THE UNIT

STAGE 2

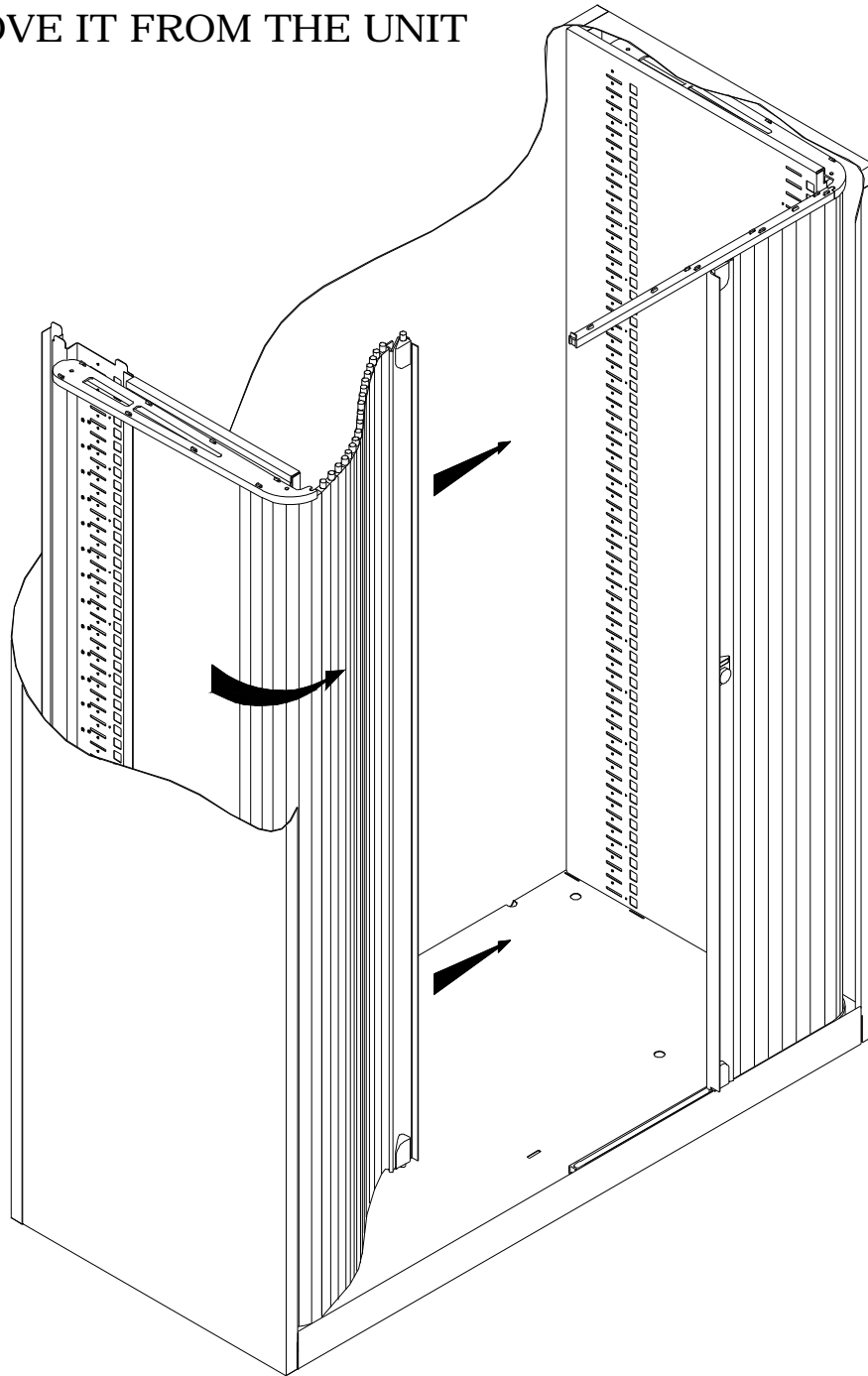

ROLL NEW SHUTTER
INTO POSITION AND
PUSH TO FULLY OPEN
POSITION

STAGE 3

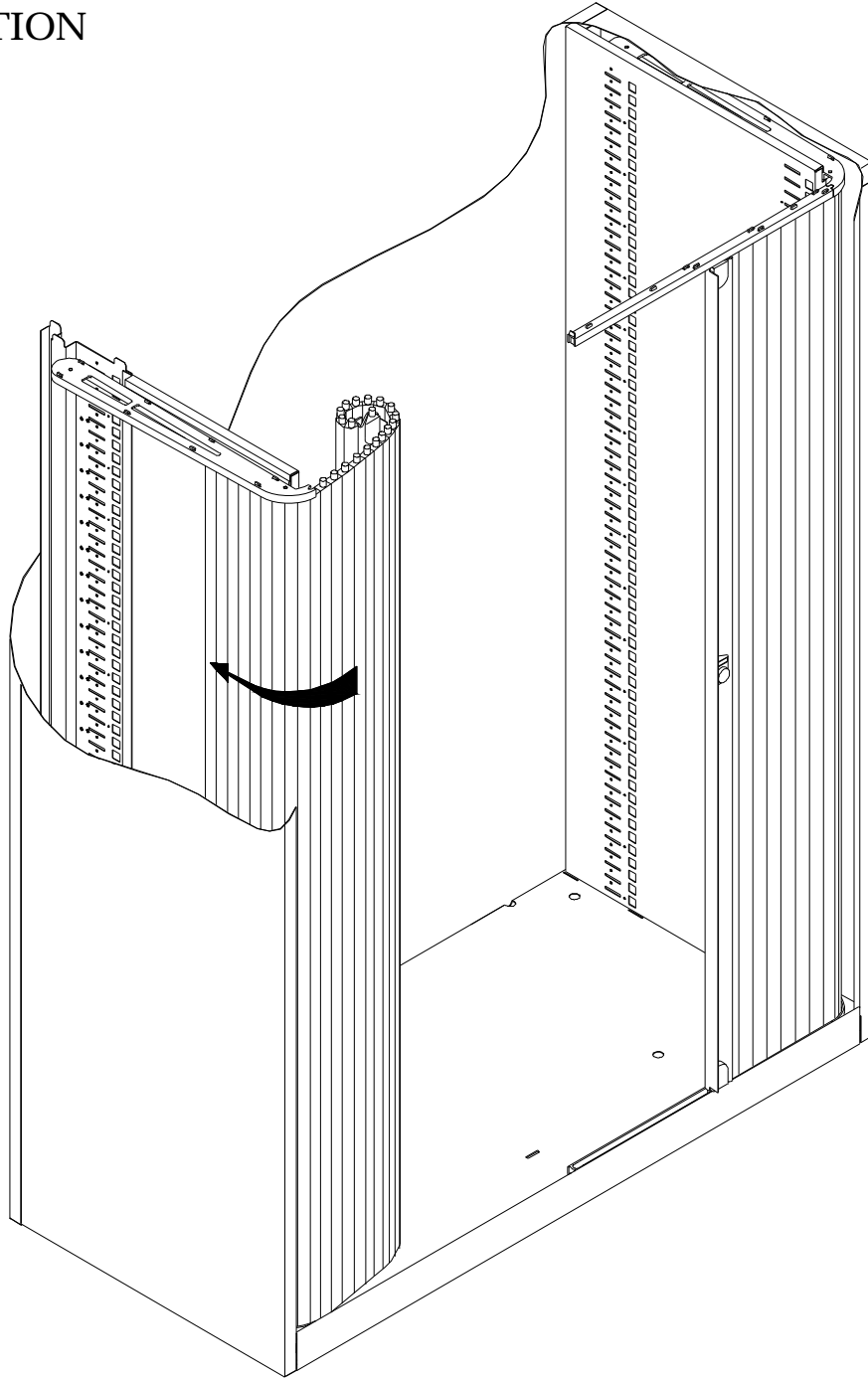

REPLACE THE STRAIGHT
TRACK SECTIONS IN THE
TOP AND BOTTOM OF THE
UNIT

STAGE 4

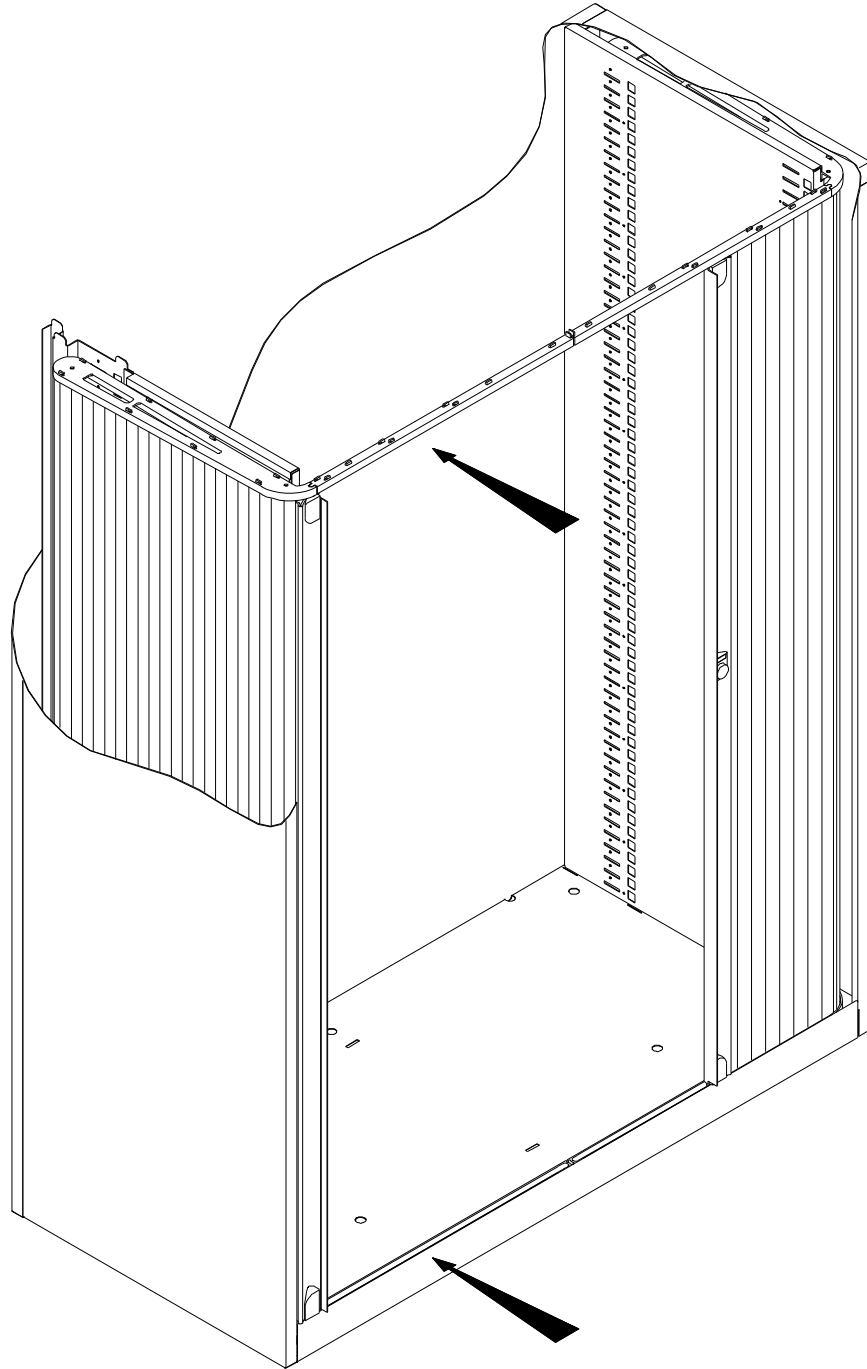

THE SAME PROCEDURE CAN
BE REPEATED FOR THE
RIGHT HAND SHUTTER IF
REQUIRED

STAGE 5

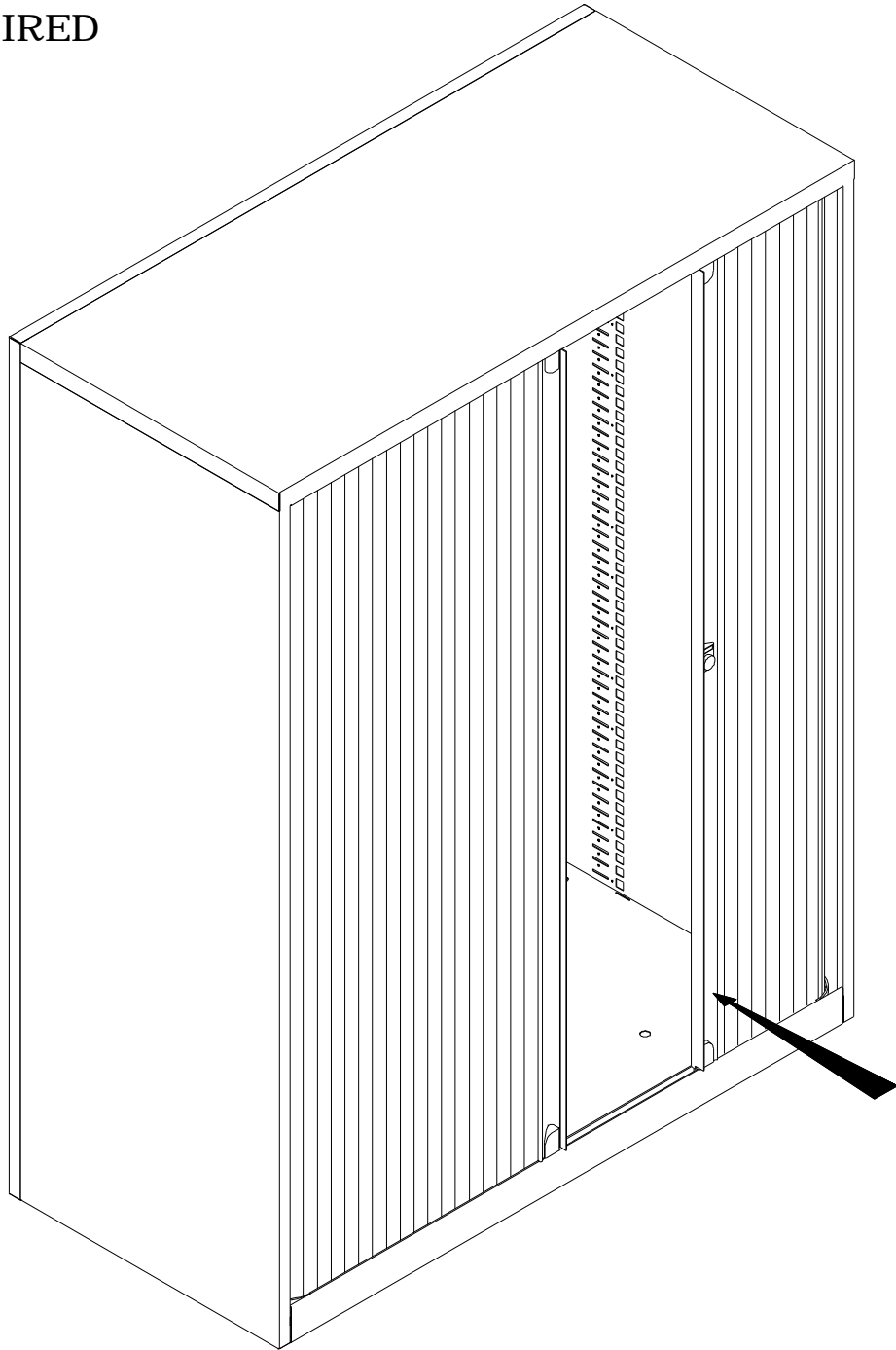

ONCE THE OPERATION IS
COMPLETE CHECK THE
ALIGNMENT OF BOTH
SHUTTERS AND THE LOCK

STAGE 6

